

# Design Details

COORITALIA

SK1N



# Design Details

# SK1N

General Walling  
Front View of SK1N System

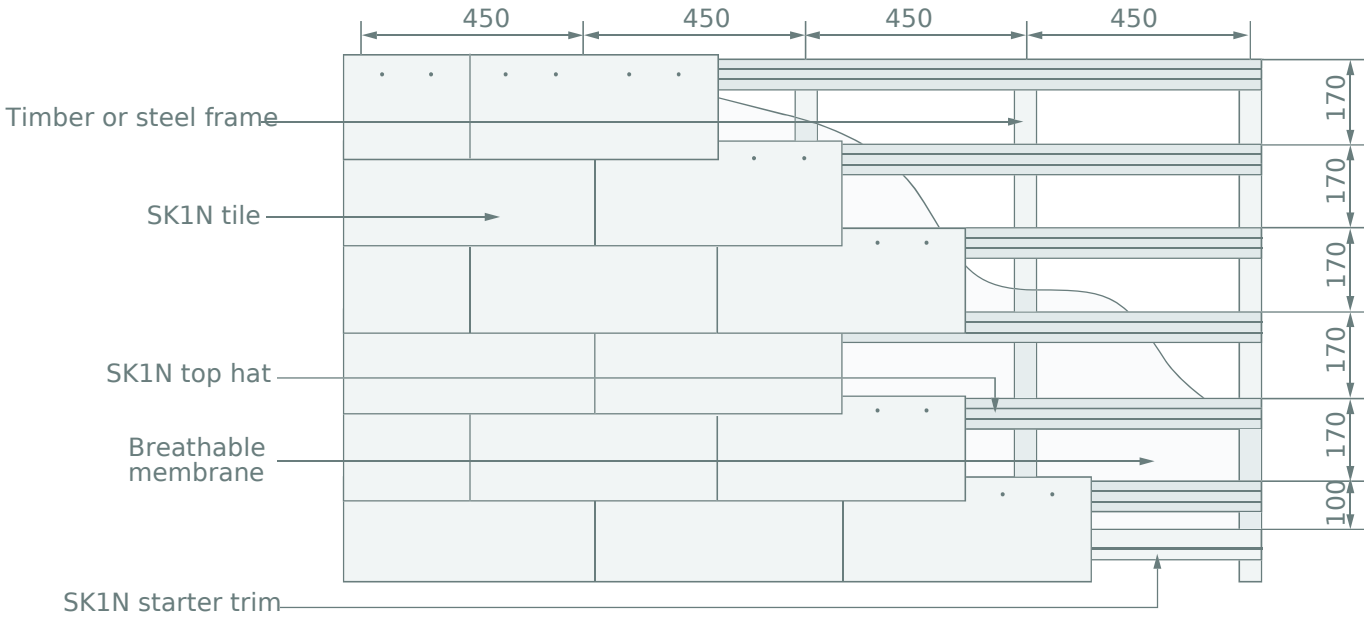

---

Plan View of SK1N System

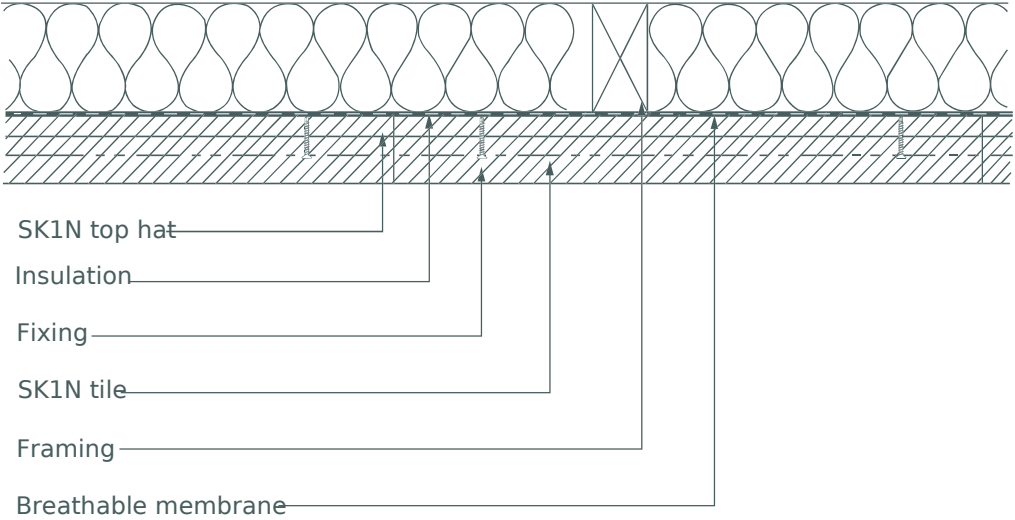

# Design Details

# SK1N

## Section View of U Shape on Timber Battens or SK1N Top Hats

U Profile with Timber Battens

U Profile with SK1N Top Hats

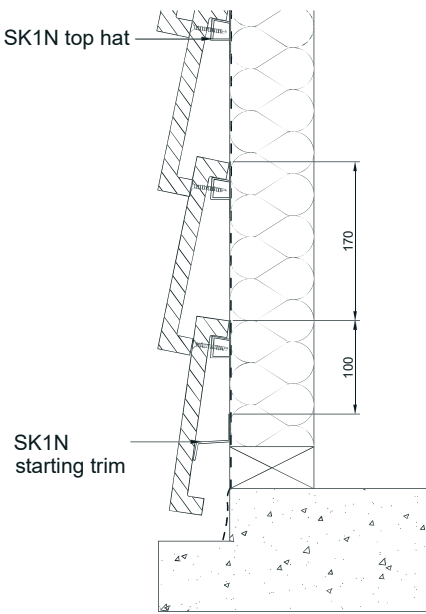
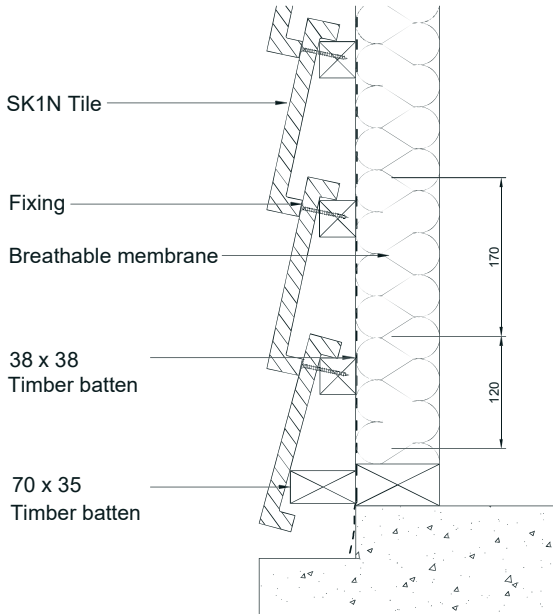

---

## Section View of L Shape on Timber Battens or SK1N Top Hats

---

L Profile with Timber Battens

L Profile with SK1N Top Hats

---

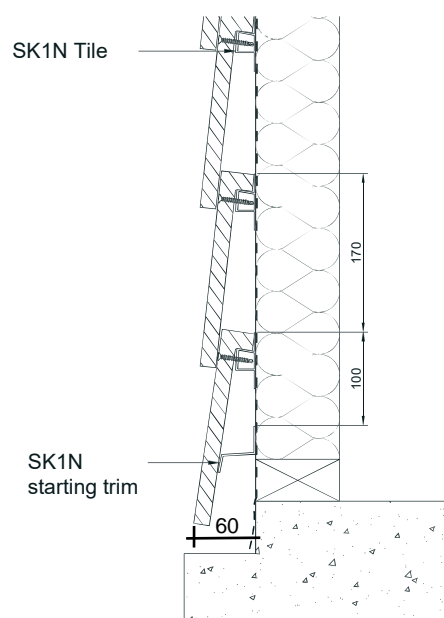
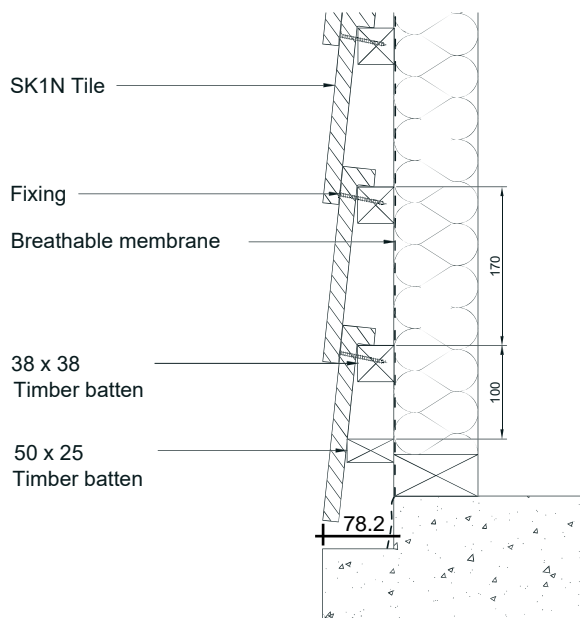

# Design Details

# SK1N

## Cavity Options

Cavity Fix with SK1N Top Hats

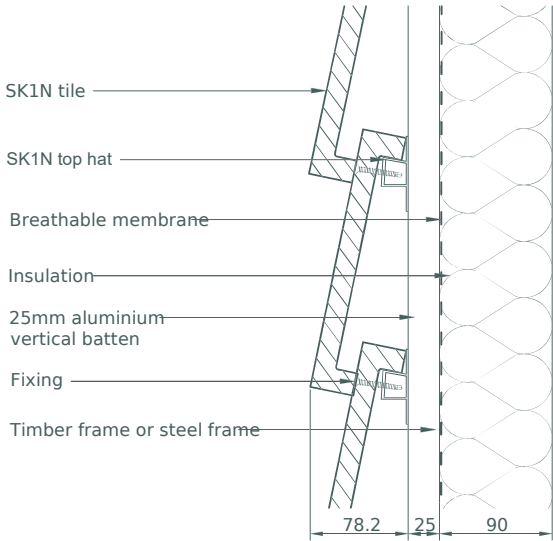

Cavity Fix with Timber Battens

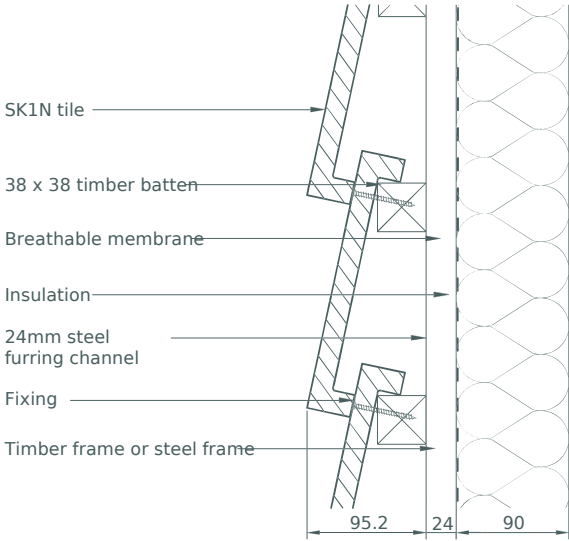

---

External Corner with Trim

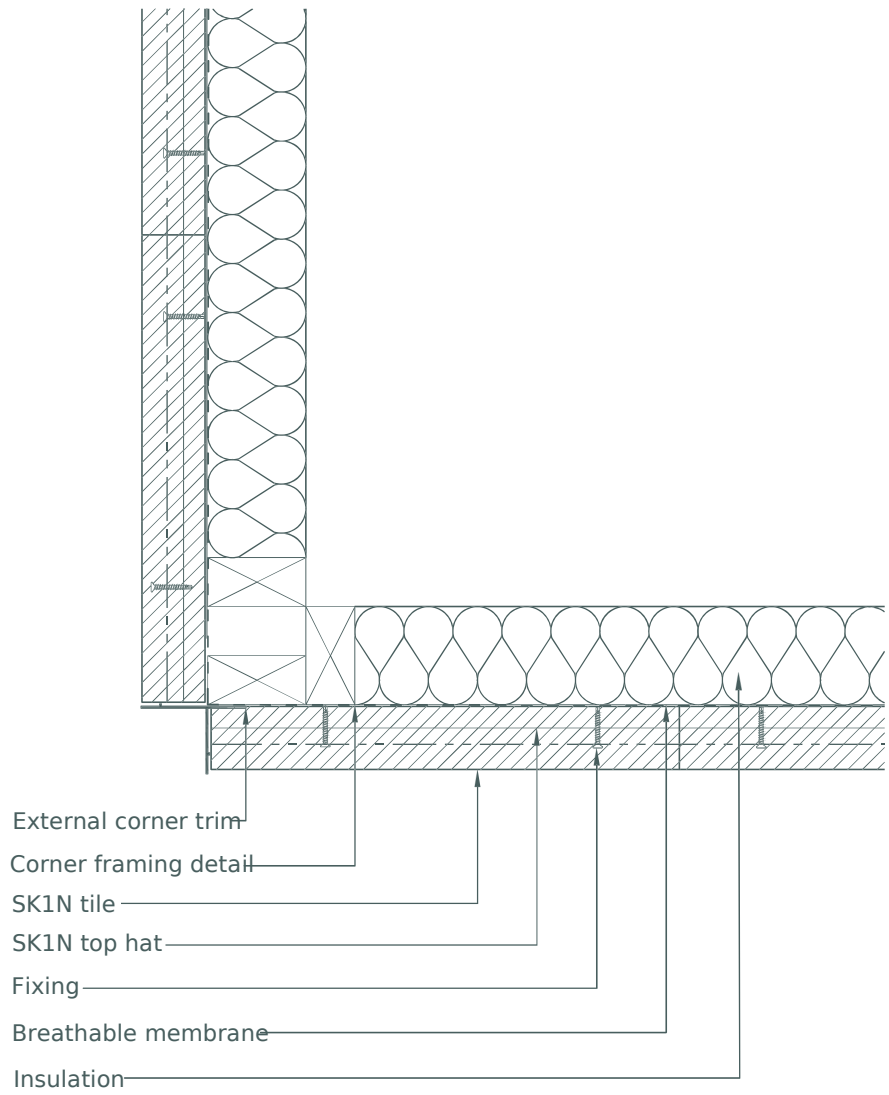

# Design Details

# SK1N

External Corner with Mitred Tiles

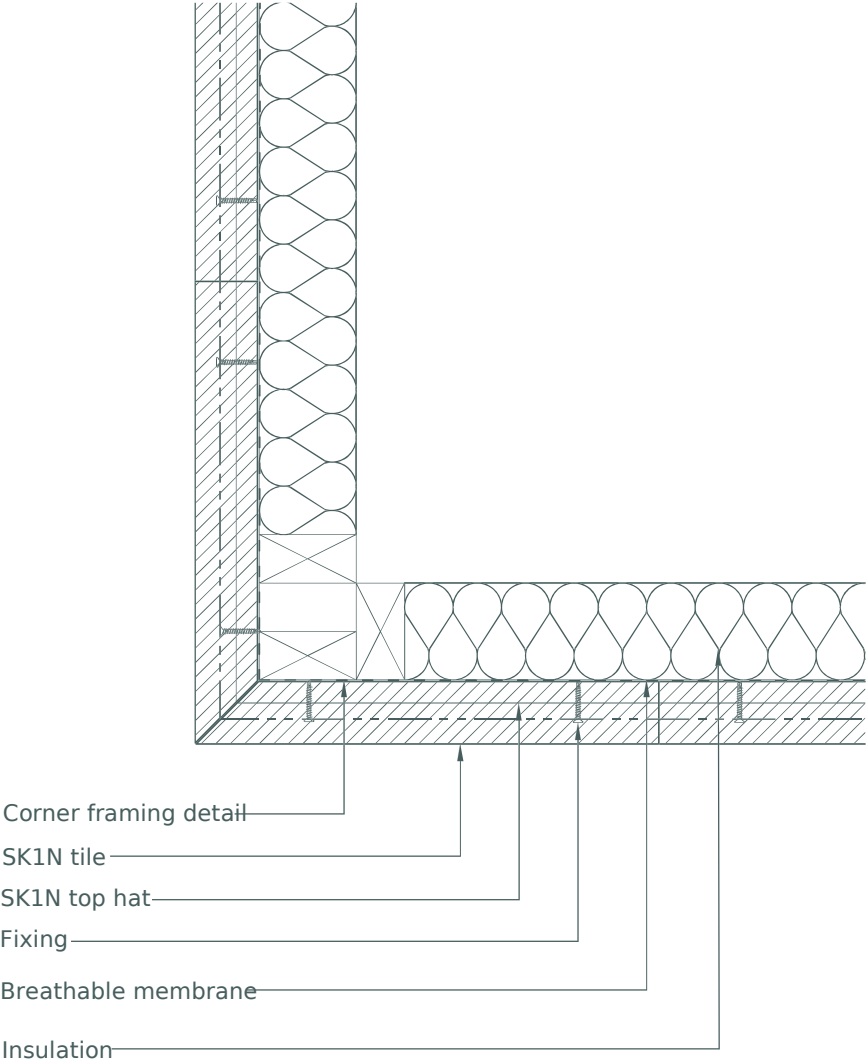



## Cutting guide for external corner tiles

### L Shape External Corner Assembly

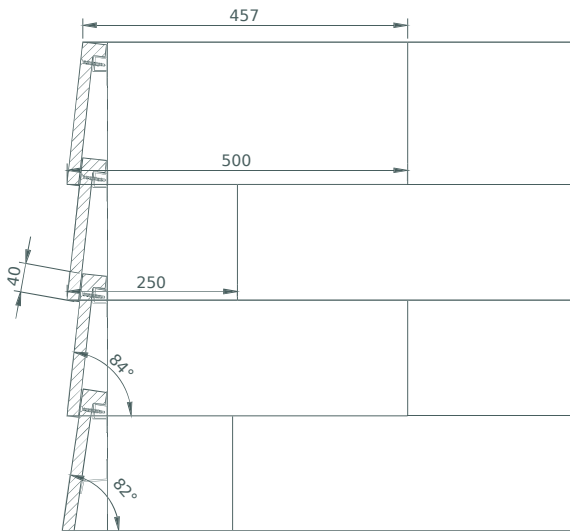

### Corner Detail Cutting Guide for L Shape

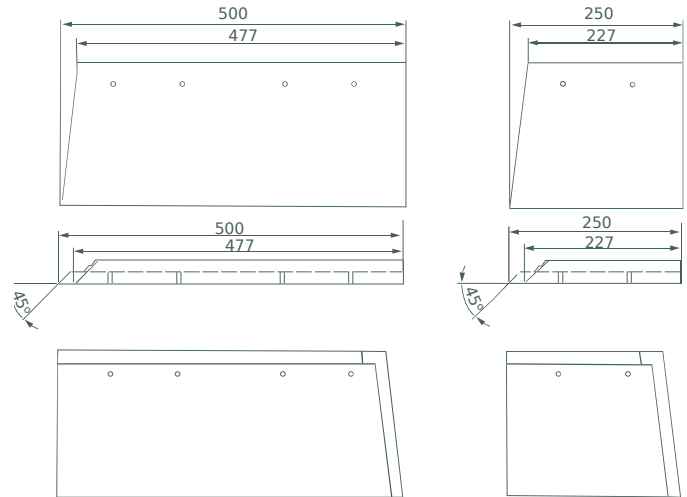

### U Shape External Corner Assembly

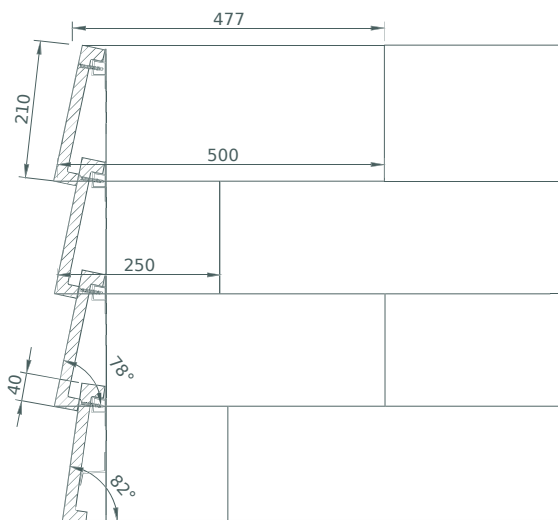

### Corner Detail Cutting Guide for U Shape

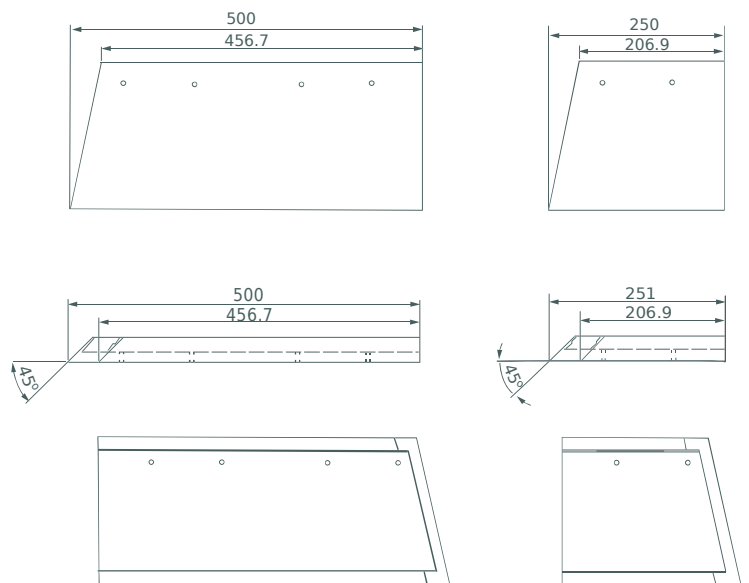

# Design Details

# SK1N

## Internal Corner

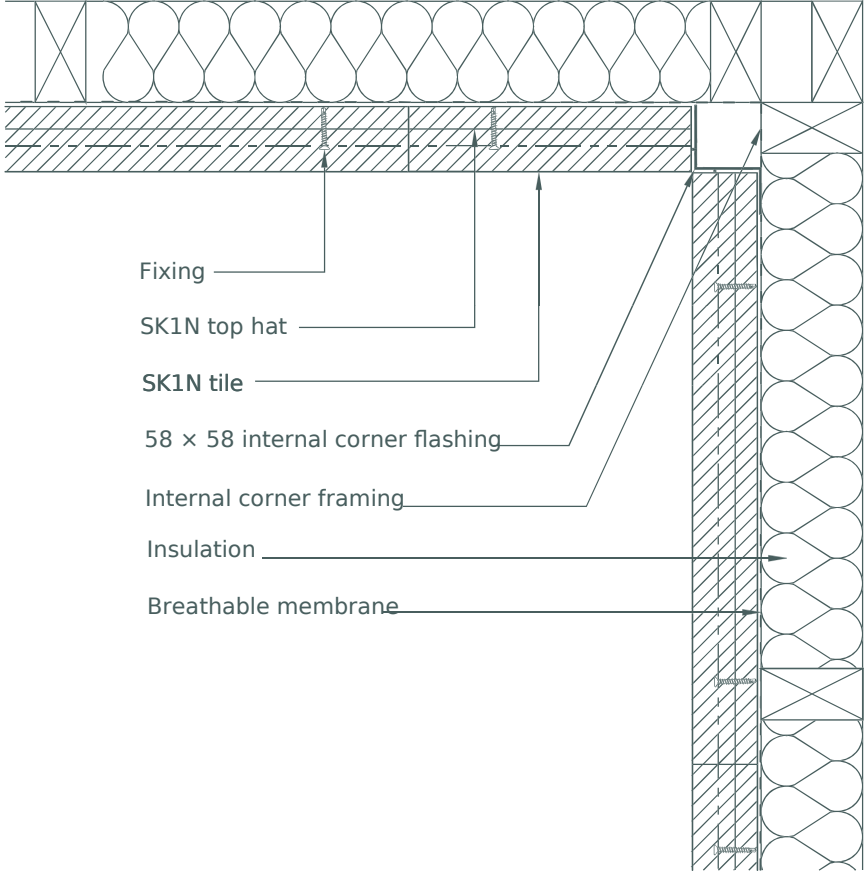

## Roof/Eave Junction

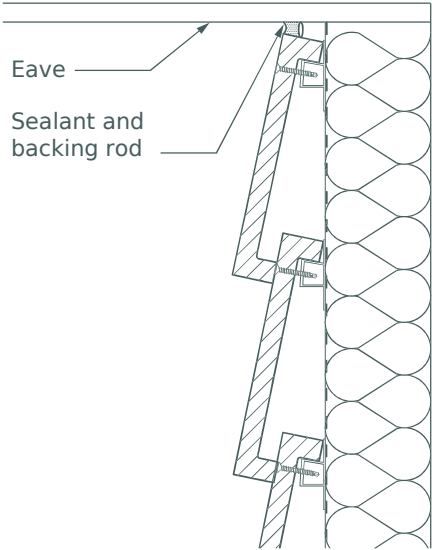

---

Roof with Box Gutter Detail

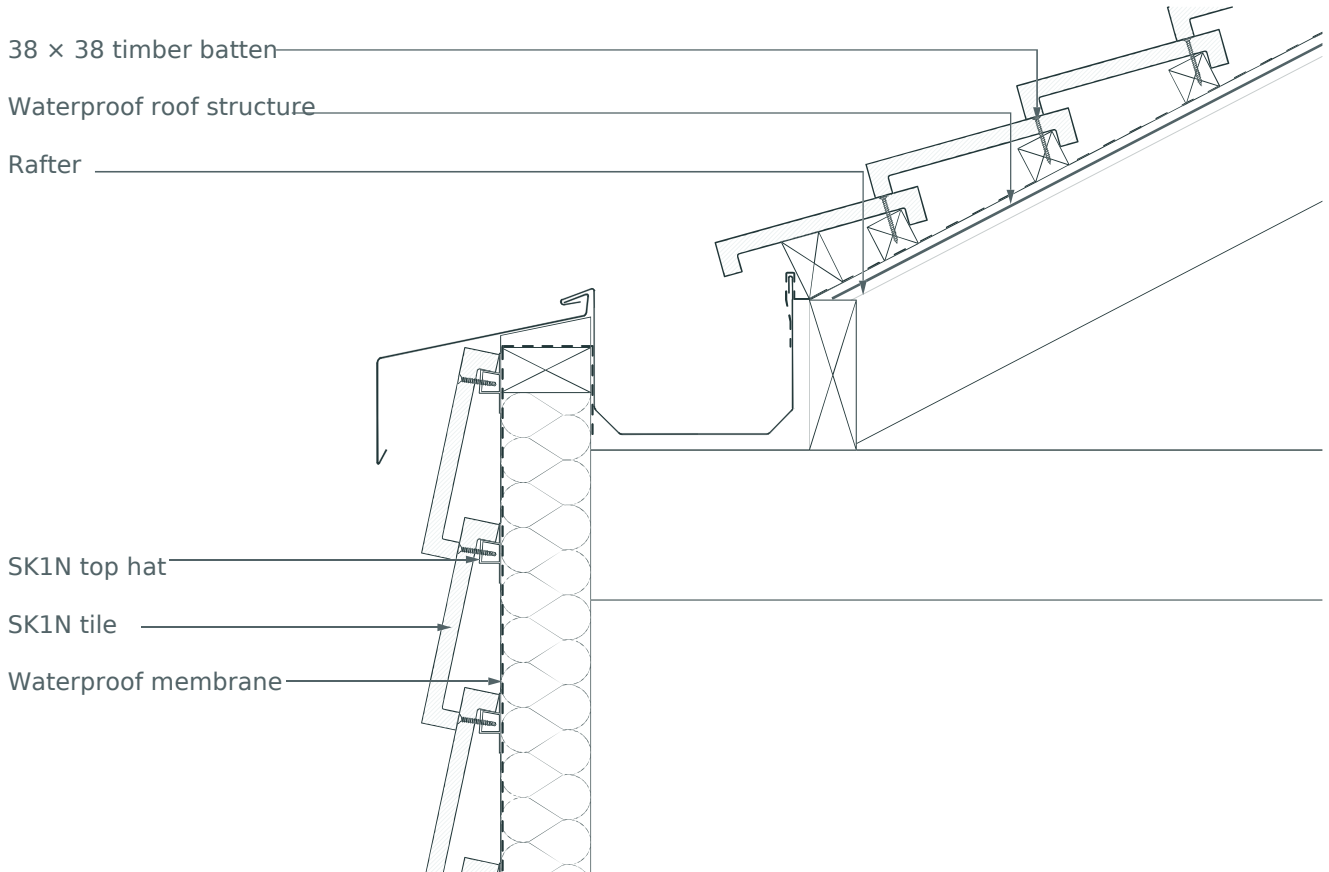

# Design Details

# SK1N

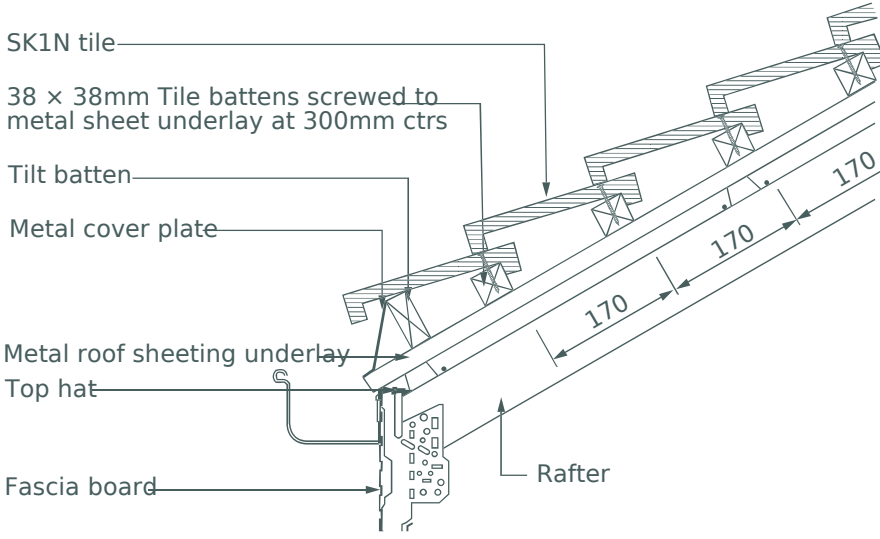
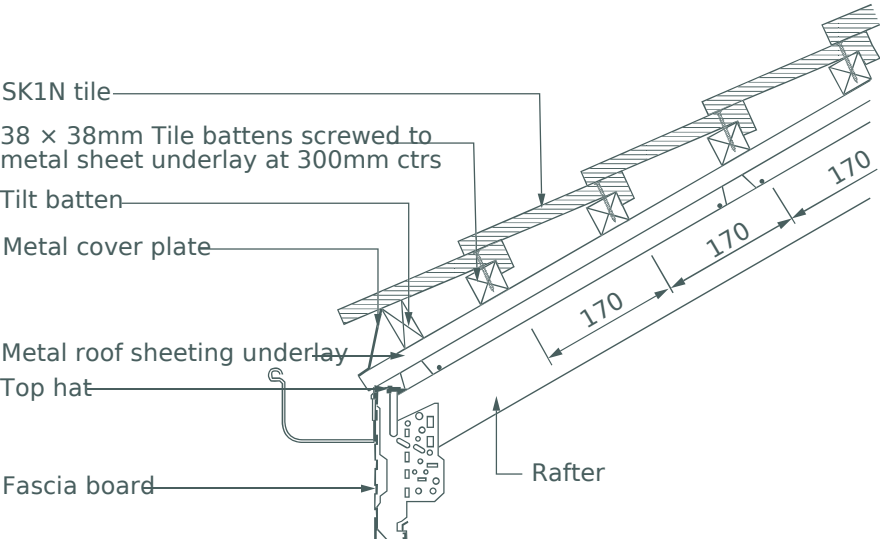

# Design Details

# SK1N

